

OWNER'S MANUAL

How to install, operate and maintain your
EcoWater Systems
Air Aspirated Iron Filter



A Marmon Water/Berkshire Hathaway Company

Models **ETF AIV-10**
ETF AIV-12

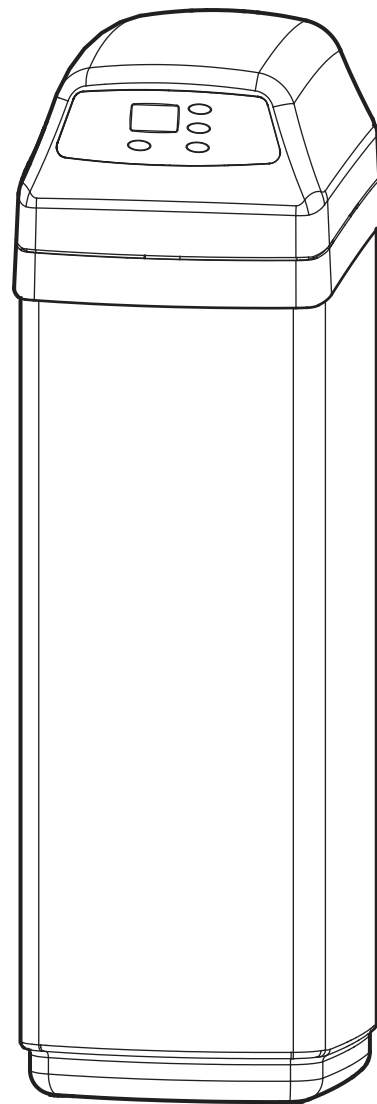

Designed, Engineered &
Assembled in the U.S.A.

EcoWater Systems LLC
P.O. Box 64420, St. Paul, MN 55164-0420
1-800-86WATER

7336313 (Rev. A 12/10/12)

TABLE OF CONTENTS

	<u>Page</u>
Specifications & Dimensions	3
Inspect Shipment	4
Safety Guides	4
Before Starting Installation	5
Typical Installation Illustrations	6
Installation Instructions	7-8
Sanitizing Procedure	9
Programming the Electronic Controller	10-11
Controller Features / Options	11-13
Routine Maintenance	13
Troubleshooting	14-16
Wiring Schematic	16
Repair Parts	17-19
Warranty	20

SPECIFICATIONS		
	Model ETF AIV-10	Model ETF AIV-12
Model Code	HAAIF	HAAIF
Amount of Zeolite Media	1.0 cu. ft.	2.0 cu. ft.
Amount of Quartz Gravel	17 lbs.	29 lbs.
Flow Rate	7 - 10 gpm	9 - 15 gpm
Minimum Backwash Flow Rate	7 gpm*	10 gpm*
Maximum Supply Water Pressure	80 psi	
Water Temperature Limits (min./max.)	40 - 120 °F	
Electrical Rating (transformer supplied)	24V, 50/60 Hz	
Contaminant Removal Limitations	Up to 10 ppm iron (except bacterial and organically bound iron**) and 3 ppm hydrogen sulfide at pH of 7.0 and higher. Up to 2 ppm Manganese***	

*Well pump must be able to provide the minimum flow for 30+ minutes.

**Consult manufacturer for applications with bacterial or organically bound iron.

***Actual performance may vary depending on local water conditions.

DIMENSIONS

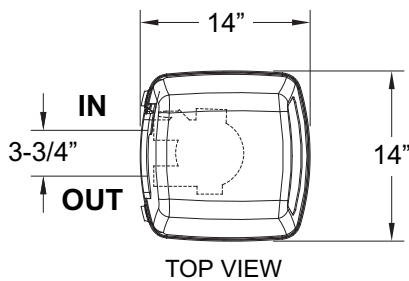

	ETF AIV-10	ETF AIV-12
Nominal Mineral Tank Size	10" dia. x 47" tall	12" dia. x 54" tall
A	57"	62-1/2"
B	50"	55-3/4"

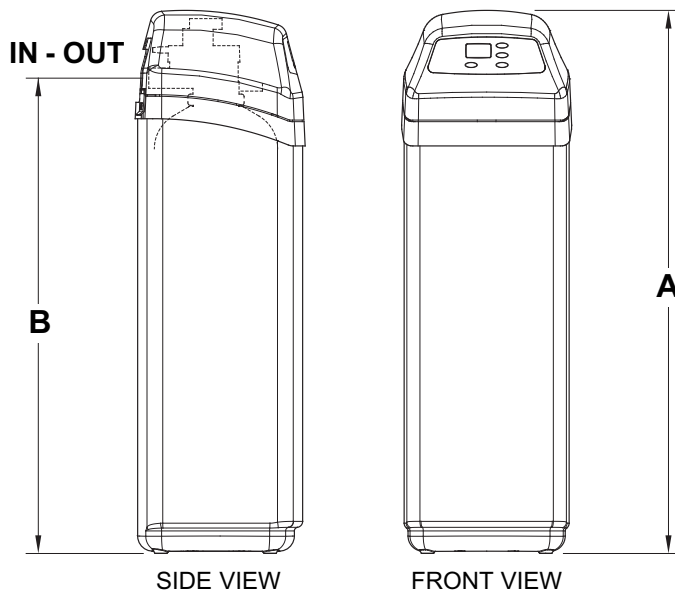

FIG. 1

INSPECT SHIPMENT

The parts required to assemble and install the Air Aspirated Iron Filter are included with the unit. Thoroughly check the water filter for possible shipping damage and parts loss. Also inspect and note any damage to the shipping carton.

Remove and discard (or recycle) all packing materials. To avoid loss of small parts, we suggest you keep the small parts in the parts bag until you are ready to use them.

SAFETY GUIDES

Follow the installation instructions carefully. Failure to install the filter properly voids the warranty.

Before you begin installation, read this entire manual. Then obtain all the materials and tools you will need to make the installation.

Check local plumbing and electrical codes. The installation must conform to them.

Use only lead-free solder and flux for all sweat-solder connections as required by state and federal codes.

Use care when handling the filter. Do not turn upside down, drop, or set on sharp protrusions.

Do not locate the filter where freezing temperatures occur. **Do not attempt to filter water over 120°F.** Freezing, or hot water damage voids the warranty.

Avoid installing in direct sunlight. Excessive sun heat may cause distortion or other damage to non-metallic parts.

The filter requires a minimum water flow of 5 gallons per minute at the inlet for backwash.

Recommended **maximum allowable inlet water pressure is 80 psi.** Use a pressure reducing valve if necessary. Be sure the addition of a pressure reducing valve will not reduce the flow to less than the 5 gallons per minute needed for backwash.

This filter controller works on **24 Volt, 60 Hz electrical power only.** Be sure to use the included transformer, and plug it into a nominal 120V, 60 Hz household outlet that is in a **dry location only**, grounded and properly protected by an over-current device such as circuit breaker or fuse.

This system is not intended to be used for treating water that is microbiologically unsafe or of unknown quality without adequate disinfection before or after the system.



European Directive 2002/96/EC requires all electrical and electronic equipment to be disposed of according to Waste Electrical and Electronic Equipment (WEEE) requirements. This directive or similar laws are in place nationally and can vary from region to region. Please refer to your state and local laws for proper disposal of this equipment.

WHERE TO INSTALL THE FILTER

- Place the filter as close as possible to the pressure tank (well system) or water meter (city water).
- Place the filter as close as possible to a floor drain, or other acceptable drain point (laundry tub, sump, standpipe, etc.). **CAUTION:** Drain water exits the hose at a fast flow rate, and at water system pressure. Be sure the hose is fastened in some manner to prevent "whipping" and splashing to prevent water damage to surrounding area.
- Connect the filter to the main water supply pipe **UPSTREAM OF** the water heater. **DO NOT RUN HOT WATER THROUGH THE FILTER.** The temperature of water passing through the filter must be less than 120°F.
- Keep outside faucets on unfiltered water to conserve filtering capacity.
- Do not install the filter in a place where it could freeze. Damage caused by freezing is not covered by the warranty.
- Put the filter in a place water damage is least likely to occur if a leak develops. The manufacturer will not repair or pay for water damage.
- A 120 volt electric outlet, to plug the included transformer into, is needed near the filter. The transformer has an attached power cable. Be sure the electric outlet and transformer are in an inside location, to protect from wet weather.
- If installing in an outside location, you must take the steps necessary to assure the filter, installation plumbing, wiring, etc., are as well protected from the elements, contamination, vandalism, etc., as when installed indoors.
- Keep the filter out of direct sunlight. The sun's heat may soften and distort plastic parts.

TOOLS, PIPE & FITTINGS, OTHER MATERIALS YOU WILL NEED

- Plastic inlet and outlet fittings included with the filter allow water flow equivalent to 1 inch nominal pipe. To maintain full valve flow, 1" pipes to and from the filter fittings are recommended. Do not reduce the pipes to less than 3/4" size.
- Use copper, brass or PEX plastic pipe and fittings.
- **ALWAYS** install the included check valve on the **INLET** pipe, immediately upstream of the filter.
- **ALWAYS** install the included bypass valve, or 3 shut-off valves. Bypass valves let you turn off water to the filter for repairs if needed, but still have water available to the house pipes.
- Drain hose 5/8" inside diameter minimum, with a garden hose connection on one end, is needed for the valve drain. See step 5 on page 8.
- If a rigid valve drain is needed, to comply with plumbing codes, you can buy the parts needed (see page 6) to connect a 5/8" minimum copper tubing drain.

PLAN HOW YOU WILL INSTALL THE FILTER

You must first decide how to run in and out pipes to the filter. Look at the house main water pipe at the point where you will connect the filter. Is the pipe soldered copper, glued plastic, or threaded brass/galvanized? What is the pipe size?

Now look at the typical installation illustration on page 6. Use it as a guide when planning your particular installation. Be sure to direct incoming, unfiltered water to the filter valve inlet fitting. The valve ports are marked **IN** and **OUT**.

INSTALLATION USING ECOWATER BYPASS VALVE

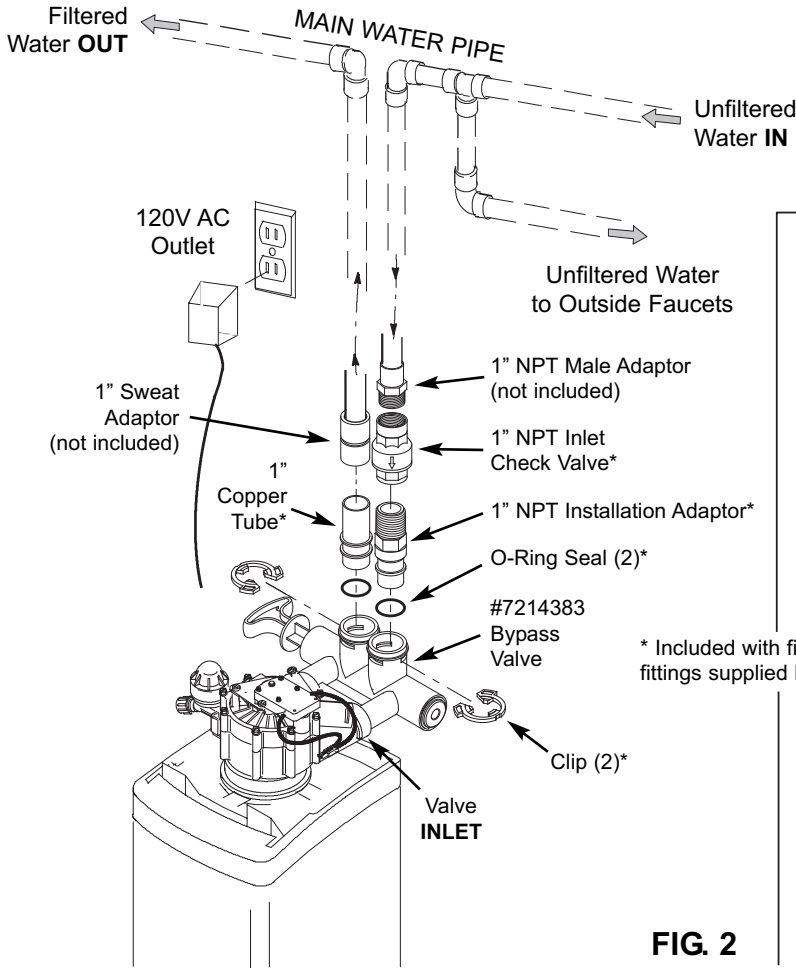
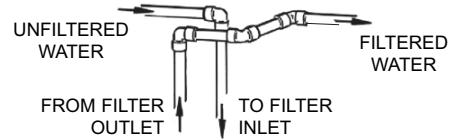

FIG. 2

CROSS-OVER

Use if water supply flows from the left. Include single or 3-valve bypass.



INSTALLATION USING 3-VALVE BYPASS

For filtered water SERVICE:

- Open the inlet and outlet valves

For unfiltered BYPASS:

- Close the inlet and outlet valves
- Open the bypass valve

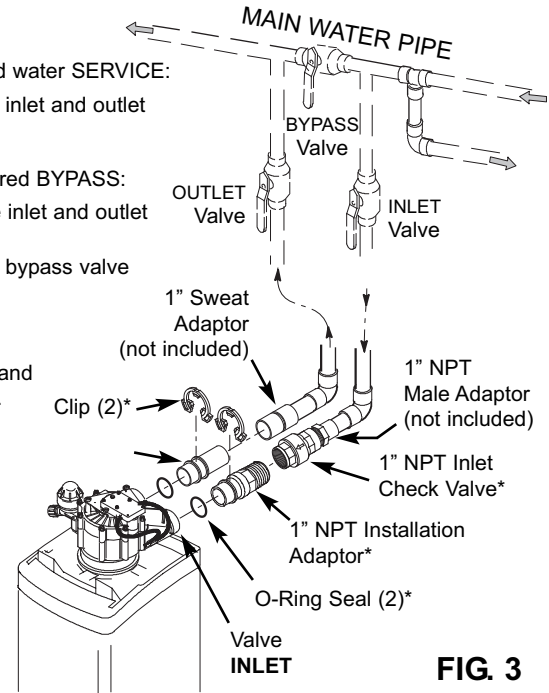
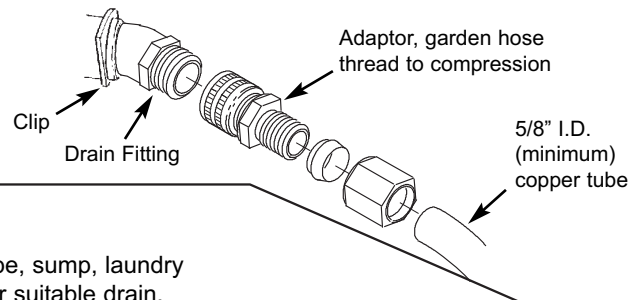

FIG. 3

CONNECTING A RIGID VALVE DRAIN TUBE

To adapt a copper tube to the filter, buy a compression fitting (garden hose thread to 5/8" I.D. minimum tube and necessary tubing from your local hardware store.



To standpipe, sump, laundry tub or other suitable drain.

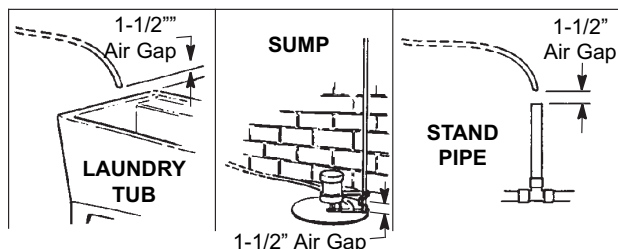
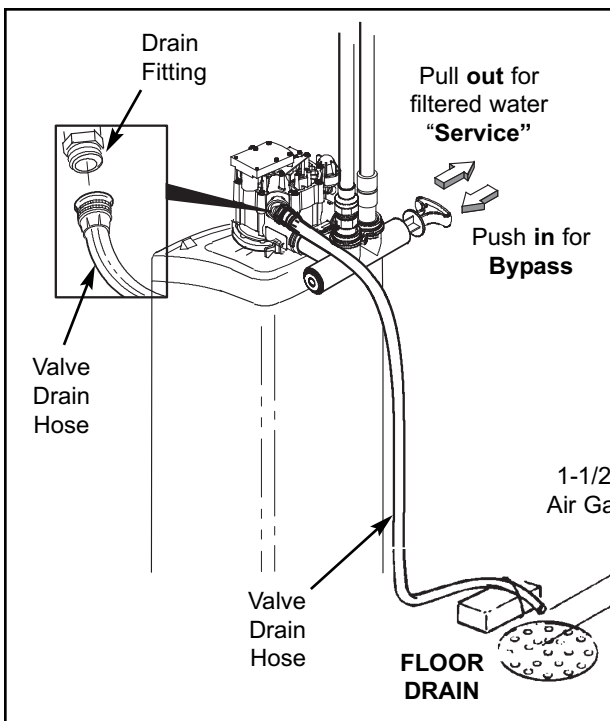

FIG. 4

1. TURN OFF WATER SUPPLY

- a. Close the main water supply valve near the well pump or water meter.
- b. Shut off the electric or fuel supply to the water heater.
- c. Open high and low faucets to drain all water from the house pipes.

2. INSTALL BYPASS VALVE AND/OR COPPER TUBES:

- a. If installing a single bypass valve, push the bypass valve, with lubricated o-ring seals in place, into the valve inlet and outlet ports (See Figures 2 & 5).

- OR -

- b. If installing a 3-valve bypass system, copper tubes, with lubricated o-ring seals in place, into the valve inlet and outlet ports (See Figures 3 & 5).
- c. Be sure the turbine support is in place in the valve outlet, as shown in Figure 6.
- d. Snap the two large plastic clips in place on the inlet and outlet ports, from the top, down (See Figure 7). Be sure they snap into place. Pull on the bypass valve, or copper tubes, to make sure they are held securely in place.

3. COMPLETE PLUMBING TO AND FROM THE FILTER

Using the “Typical Installation Illustration” on page 6 as a guide, observe all of the following cautions while you connect inlet and outlet plumbing:

- Be sure incoming, **unfiltered water** is directed to the valve **INLET** port.
- **Be sure to install the included check valve on the INLET pipe**, immediately upstream of the filter, as shown in the “Typical Installation Illustration” on page 6. Note the direction of the flow arrow on the check valve.
- Be sure to install bypass valve(s).
- If making a soldered copper installation, do all sweat soldering before connecting pipes to the filter fittings. Torch heat will damage plastic parts.
- Use pipe joint compound on all external pipe threads.
- When turning threaded pipe fittings onto plastic fittings, use care not to cross-thread.
- Support inlet and outlet plumbing in some manner (use pipe hangers) to keep the weight off of the valve fittings.

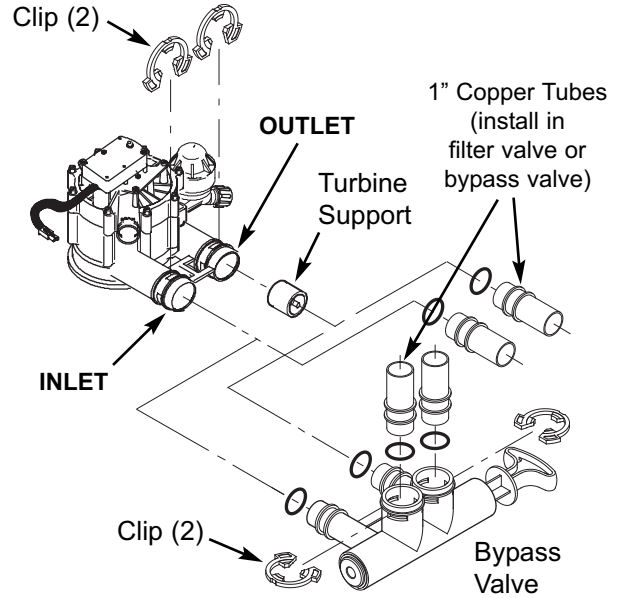

FIG. 5

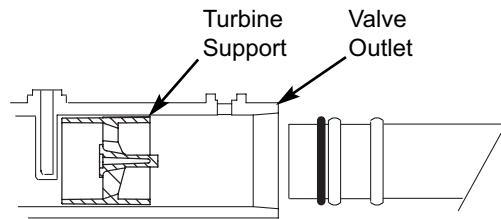

FIG. 6

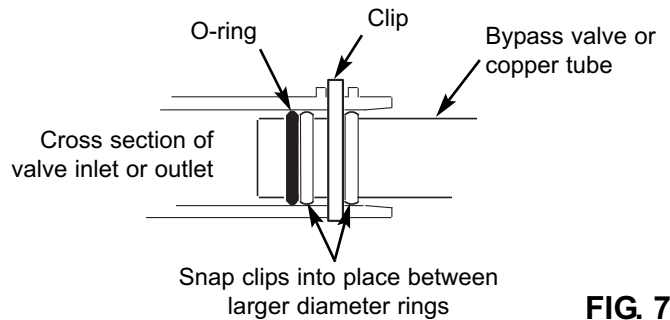
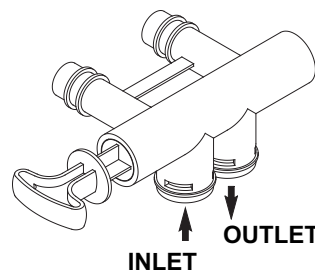
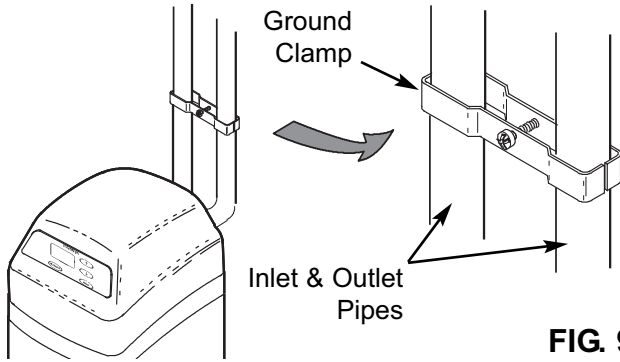

FIG. 7



Turn the bypass valve downward if connecting to floor level plumbing

FIG. 8



4. INSTALL GROUND CLAMP (IF NEEDED):

If the home's cold water piping is being used for electrical grounding, a 3 valve bypass system maintains ground continuity. If you are using a single plastic bypass valve, install the included ground clamp, as shown in Figure 9, to maintain electrical ground continuity in the house cold water piping. Be sure the pipes are clean, under the clamps, to assure good contact.

5. INSTALL VALVE DRAIN HOSE

- Take a length of 5/8" inside diameter garden hose and attach to the valve drain fitting (See Figure 4 on page 6).
- Locate the other end of the hose at a suitable drain point (floor drain, sump, laundry tub, etc.). Check and comply with local codes. Refer to Figure 4 on page 6 if codes require a rigid pipe drain run.

IMPORTANT: Use high quality, thick wall hose that will not easily kink or collapse. The filter will not backwash properly if water cannot exit this hose during recharges.

- Tie or wire the hose in place at the drain point. Water pressure will cause it to whip during the backwash portion of the recharge cycle. Also provide an air gap of at least 1-1/2" between the end of the hose and the drain point. An air gap prevents possible siphoning of sewer water, into the filter, if the sewer should back up.
- If raising the drain hose overhead is required to get to the drain point, do not raise higher than 8 feet above the floor. Elevating the hose may cause a back pressure that could reduce backwash flow and proper mineral bed cleaning.

6. FLUSH PIPES AND TEST FOR LEAKS

CAUTION: To avoid water or air pressure damage to filter inner parts, be sure to do the following steps exactly as listed:

- Fully open two filtered water faucets, one cold and one hot, nearby the filter.

- Place bypass valve(s) into "bypass" position. On a single valve, slide the stem inward to BYPASS (See Fig. 4 on page 6). On a 3 valve system, close the inlet and outlet valves, and open the bypass valve (See Fig. 3 on page 6).
- Fully open the house main water pipe shutoff valve. Observe a steady flow from both opened faucets.
- Close both faucets.
- Check your plumbing work for leaks and, if any are found, fix right away. Be sure to observe previous caution notes.
- Turn on the gas or electric supply to the water heater. Light the pilot, if applicable.

7. CONNECT TO ELECTRICAL POWER:

The filter works on 24 volt, 60 Hz electric power. The included transformer changes standard 120 volt AC house power to 24 volts. Plug the transformer into a 120V, 60 Hz electrical outlet. Be sure the outlet is always "live" so it can not be switched off by mistake.

8. PROGRAM THE CONTROLLER

See pages 10-11 for instructions to program the electronic controller.

9. START UP PROCEDURE

- Confirm that the filter's main valve is in the "service" position ("S" on the cam).
- Place bypass valve(s) into "service", EXACTLY as follows:
 - **Single Bypass Valve:** SLOWLY, pull the valve stem outward to "service" position, pausing several times to allow the filter to pressurize slowly.
 - **3 Valve Bypass:** Fully close the bypass valve and open the outlet valve. SLOWLY, open the inlet valve, pausing several times to allow the filter to pressurize slowly.
- Check all connections for leaks.
- Push and hold the RECHARGE button until the filter starts a RECHARGE NOW cycle. Verify that the valve advances to "backwash" (BW) position.
- Allow the unit to remain in "backwash" (BW) while air is purged and water exits the drain line. Ensure that the drain line is secure and will withstand the mix of air and water exiting.
- Allow the unit to complete the 15 minute "backwash" cycle and automatically advance to the "aspirate" (A) position. Allow it to remain there as it aspirates air into the mineral tank. After 75 minutes, the filter will then automatically return to "service". Start up is complete.

DESCRIPTION OF OPERATION

Service water enters the filter and passes through air captured at the top of the mineral tank. Dissolved iron, manganese and sulphur are oxidized and then removed by the media in the tank. When the system recharges, it first backwashes the contaminants to the

drain, then empties the tank of water, replacing it with air drawn through the aspirator. When the system returns to "service", the water pressure will compress the air in the mineral tank and leave an 8-14" head of air on the top of the tank.

SANITIZING PROCEDURE

Care is taken at the factory to keep your water filter clean and sanitary. Materials used to make the filter will not infect or contaminate your water supply, and will not cause bacteria to form or grow. However, during shipping, storage, installing and operating, bacteria could get into the filter or media. For this reason, sanitizing as follows is suggested* when installing.

1. Obtain pharmaceutical grade 12% hydrogen peroxide solution. One quart (0.95 L) is required for a 10" filter, 2 quarts (1.9 L) for a 12" filter.
2. Remove air inlet screen from check valve on the valve's nozzle & venturi assembly (See Figure 10).
3. Connect a length of 3/8 I.D. tubing to the barb on the aspirator check valve (See Figure 11).
4. Insert the free end of the tubing into the hydrogen peroxide container.
5. Push and hold the RECHARGE button until the filter starts a RECHARGE NOW cycle. The filter will backwash for 15-17 minutes, then advance automatically to the "aspirate" position. It will draw the hydrogen peroxide into the filter and pass it through the zeolite media, cleaning and sanitizing the media.
6. Allow the filter to draw air for the remainder of the time in the "aspirate" cycle after the hydrogen peroxide has been drawn into the filter.
7. The filter will return to "service" automatically when the "aspirate" cycle is complete.
8. Remove tubing and reinstall the aspirator inlet screen onto the barbed fitting on aspirator check valve.
9. Cleaning/sanitizing process is complete.

***NOTE:** Sanitizing is recommended by the Water Quality Association for disinfecting. On some water supplies, they suggest periodic sanitizing.

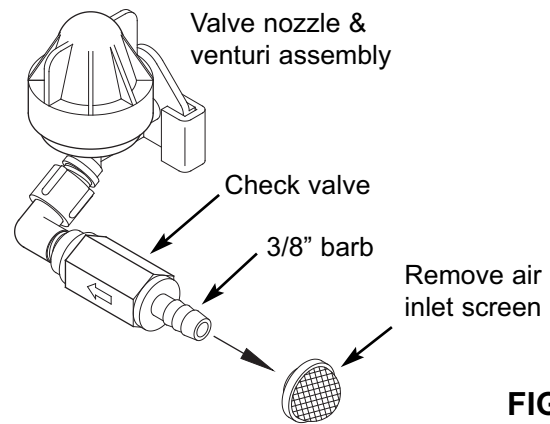

FIG. 10

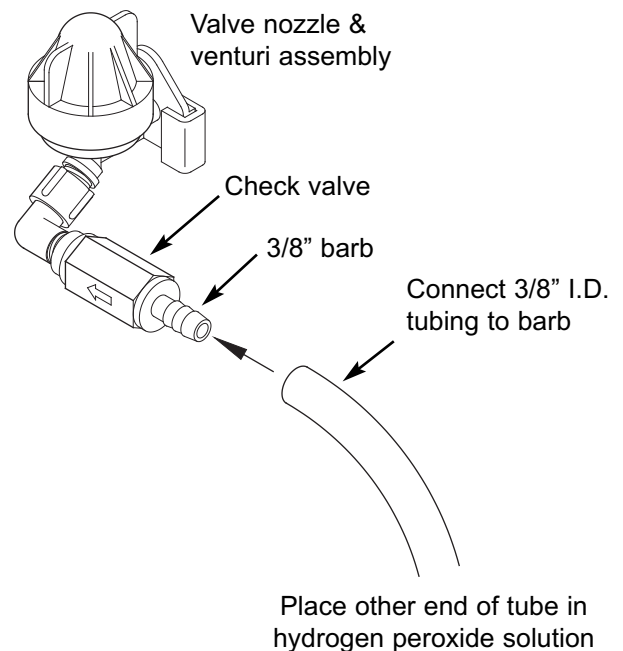

FIG. 11

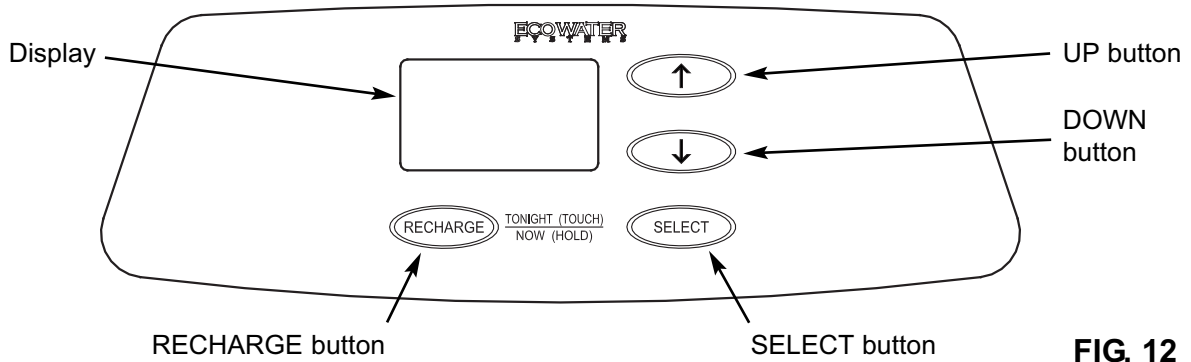

FIG. 12

CONTROLLER SETTINGS REQUIRED

upon installation, and after an extended power outage.

When the transformer is plugged into the electrical outlet, a model code (HAAIF) and a test number (example: J2.0), are briefly shown in the display. Then the words "PRESENT TIME" appear and 12:00 PM begins to flash.



FIG. 13

A. SET PRESENT TIME OF DAY

If the words "PRESENT TIME" do not show in the display, press the SELECT button several times until they do.

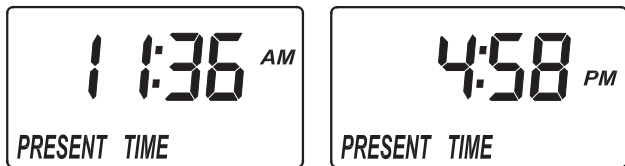

FIG. 14

1. Press the ↑ UP or ↓ DOWN buttons to set the present time. Up moves the display ahead; down sets the time back. Be sure AM or PM is correct.

NOTE: Press buttons and quickly release to slowly advance the display. Hold the buttons down for fast advance.

2. When the correct time is displayed, press the SELECT button, and the display will change to show the "Days between recharge" screen.

B. SET DAYS BETWEEN RECHARGES

1. If you completed the previous step, the word "RECHARGE" should show in the display (See Figure 15). Otherwise, press the SELECT button several times until it does.

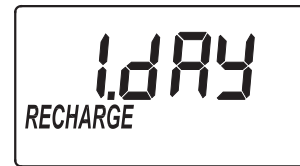

FIG. 15

2. The default setting is 1 day. This means that the filter will recharge every day. To change the number of days between recharges, use the ↑ UP or ↓ DOWN buttons to adjust from 1 to 99 days.

Use the table below to determine the number of days between recharges, based on the number of people in the household and the iron ppm (parts per million) in the water supply.

Number of People	Iron (parts per million)	
	1 - 2	3 - 20
1 - 3	2 days	1 day
4 - 7	1 day	1 day

NOTE: If the water supply has high turbidity (sand, silt, sediments, etc.) set to recharge more often than the table shows.

3. When the desired number of days is displayed, press the SELECT button, and the display will change to show the "Recharge Time" screen.

continued on next page

C. SET RECHARGE START TIME

1. If you completed the previous step, the words "RECHARGE TIME" should show in the display (See Figure 16). Otherwise, press the SELECT button several times until they do.



FIG. 16

2. The filter's default recharge start time is 12:00 AM. This is normally a time of day when water is not being used in the household. If you have a water softener or another filter installed, the recharge start times should be offset to assure adequate water flow and pressure. For example, if the water softener is set to begin recharge at 2:00 AM, set the filter to start recharge at 12:00 AM, or 4:00 AM. Use the ↑ UP or ↓ DOWN buttons to adjust the recharge start time.
3. When the desired recharge time is displayed, press the SELECT button, and the display will change to show the normal run time display.

CONTROLLER FEATURES / OPTIONS

NORMAL OPERATION

During normal operation, the present time of day shows in the display.

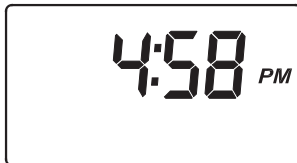

FIG. 17

RECHARGE NOW

For times when you expect to use more water than usual, it may be desirable to perform a manually initiated recharge. To manually start a recharge cycle, press and hold the RECHARGE button for a few seconds, until "RECHARGE NOW" flashes in the display. The filter begins an immediate backwash. Once started, you cannot cancel this recharge. Avoid using hot water during this time, as the water heater will refill with unfiltered water.



FIG. 18

POWER OUTAGE MEMORY

If electrical power to the filter's control is lost, internal memory will maintain most settings such as the days between recharge and recharge time. However, unless the power outage was very brief, the clock's present time will need to be reset. During a power outage, the display will be blank and the filter will not recharge. When electrical power is restored:

1. Check the display.
- 2a. If the present time is displayed steadily (not flashing), the controller did not lose time and you do not need to reset the clock.
- 2b. If a time is flashing in the display, then the clock needs to be reset to the correct present time. See "Set Present Time of Day" on page 10. The flashing display is to remind you to reset the clock. If you do not reset the clock, then recharges will most likely occur at the wrong time of day.

NOTE: If the filter was recharging when power was lost, it will finish the cycle when power returns.

VACATION CONTROL

1. **Before going on vacation**, or other long absence, press (but do not hold) the RECHARGE button, so that "VAC" begins to flash in the display. The timer continues to keep time, but recharges will not occur, saving water.



FIG. 19

2. **When you return**, press the RECHARGE button again. This cancels the flashing "VAC" and returns the filter to normal service. You must remember to do this, or the filter will not recharge.

RECHARGE CYCLE TIME ADJUSTMENTS

The default setting for **backwash** and **aspirate** times of the recharge cycle are factory set for maximum performance of the filter. Use the following procedures to check for correct cycle times, or to change, if desired. It is recommended that only trained technicians should change the time settings.

NOTE: Fill and brine times are adjustable, but set at the factory to zero. It is recommended to leave these settings at zero, unless the filter is used in a custom application by the installer.

A. ADJUSTABLE BACKWASH TIME

1. Press and hold for 3 seconds the SELECT button, until the display shows "000 - -", then press the SELECT button again to display the backwash time adjust screen (See Figure 20).

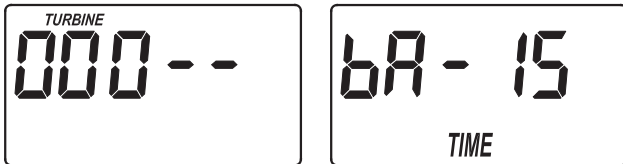

FIG. 20

2. The default setting is 15 minutes. Use the ↑ UP or ↓ DOWN buttons to adjust backwash time from 0 to 99 minutes.
3. When the desired backwash time is displayed, press the SELECT button, and the display will change to show the next cycle time adjust screen.

B. ADJUSTABLE ASPIRATE TIME

1. If you completed the previous step, the aspirate time adjust screen should show in the display (See Figure 21). Otherwise, press and hold for 3 seconds the SELECT button, until the display shows "000 - -", then press the SELECT button twice to display the aspirate time adjust screen.

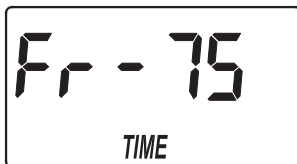

FIG. 21

2. The default setting is 75 minutes. Use the ↑ UP or ↓ DOWN buttons to adjust aspirate time from 0 to 99 minutes.
3. When the desired aspirate time is displayed, press the SELECT button twice, and the display will change to show the normal run time display.

AUXILIARY OUTPUT CONTROL

The electronic controller's auxiliary output may be used to operate various types of external equipment, such as a chlorine generator or chemical feeder. It provides a 24V DC, up to 500 mA, current from terminal J4 on the electronic control board (see Schematic on the next page). The table below explains the choices available for when the auxiliary output will be on during various portions of the recharge cycle:

SELECTION	NAME	AUXILIARY OUTPUT FUNCTION
OFF	Off	Remains off indefinitely.
BP	Bypass	On during the entire recharge.
CL	Chlorine	On during the brine draw portion of the recharge (softeners only).
FS	Flow Switch	On when water is flowing past the turbine (on units with a turbine). It will shut off 8 seconds after water flow stops.
CF	Chemical Feeder	After the set volume of water has flowed past the turbine (on units with a turbine), turns on for the time set (see Steps 4 & 5, on the next page, to set volume and time).
FR	Aspirate	On during the aspirate portion of the recharge.

The default is OFF. If you wish to change to one of the other selections shown in the table above:

1. Press and hold the SELECT button until "000 - -" shows in the display.
2. Press the SELECT button three times and "Ctrl" will flash in the display.

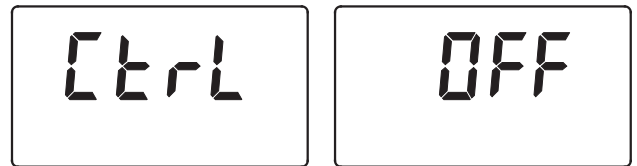

FIG. 22

3. Use the ↑ UP or ↓ DOWN buttons to display the desired selection, then press the SELECT button. If you selected anything other than CF, the display will return to the normal run (time of day) screen. If setting to CF (Chemical Feeder), there will be two additional settings to make for operating the chemical feeder in Steps 4 and 5, on the next page.

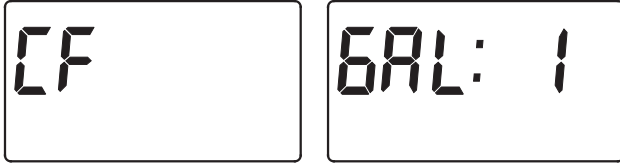

FIG. 23

4. CHEMICAL FEEDER TRIP VOLUME: If you have set the auxiliary output control to CF (Chemical Feeder), you will need to set the volume of water which must flow past the turbine before the auxiliary output is turned on. With the alternating screens in Fig. 23 shown, use the ↑ UP or ↓ DOWN buttons to set the trip volume, in gallons.

Then press the SELECT button to display the screen shown in Fig. 24.



FIG. 24

5. CHEMICAL FEEDER TIME: Use the ↑ UP or ↓ DOWN buttons to set the length of time, in seconds, that the auxiliary output will be turned on. Then press the SELECT button to accept and return to the normal run (time of day) screen.

ROUTINE MAINTENANCE

CLEANING THE NOZZLE & VENTURI

A clean nozzle & venturi (See Figure 25) is a necessity for the water filter to work properly. This small component creates the suction to aspirate (bring air into) the mineral tank during recharges. If it should become plugged with sand, silt, dirt, etc., the water filter will not work to remove iron from the water.

To get access to the nozzle & venturi, remove the water filter's top cover. Put the bypass valve(s) into the bypass position. Be sure the water filter's main valve is in "service" position (no water pressure at nozzle & venturi). Then, holding the nozzle & venturi housing with one hand, unscrew the cap. Do not lose the o-ring seal. Lift out the screen support and screen. Then, remove the nozzle & venturi disc, gasket and flow plug. Wash the parts in warm, soapy water and rinse in fresh water. Be sure to clean both the top and bottom of the nozzle & venturi disc. If needed, use a small brush to remove iron or dirt. Do not scratch, misshape, etc., surfaces of the nozzle & venturi.

Gently replace all parts in the correct order. Lubricate the o-ring seal with silicone grease and locate in place. Install and tighten the cap by hand, while supporting the housing. Overtightening may break the cap or housing. Put the bypass valve(s) into "service" position.

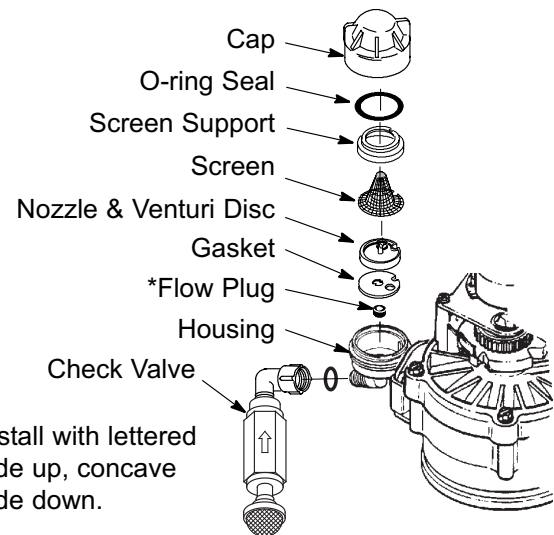

IMPORTANT: Be sure small hole in the gasket is centered directly over the small hole in the nozzle & venturi housing. Be sure the numbers are facing up

FIG. 25

Recharge the filter and advance the valve to the "aspirate" (A) position. Remove the screen from the barbed fitting on the inlet of the check valve and determine whether there is suction. Put the screen back in place when finished checking.

AUTOMATIC ELECTRONIC DIAGNOSTICS

This filter has a self-diagnostic function for the electrical system. The computer monitors electronic components and circuits for correct operation. If a malfunction occurs, an error code appears in the display.

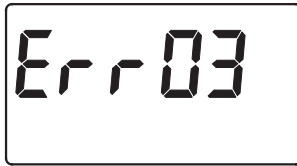

FIG. 26

The chart below shows the error codes that could appear, and the possible malfunctions for each code.

Code	Possible Problems
Err01	Motor, Valve Position Switch
Err03	Motor, Valve Position Switch, Wire Harness
Err04	Valve Position Switch
Err05	Electronic Control Board (PWA)

While an error code appears in the display, all buttons are inoperable except the SELECT button. SELECT remains operational so the service person can perform the Manually Initiated Electronic Diagnostics to further isolate the problem.

TO REMOVE AN ERROR CODE:

1. Unplug the transformer.
2. Correct the problem.
3. Plug the transformer back in.
4. Wait for at least 8 minutes while the timer operates the valve through an entire cycle. The error code will return if the problem was not corrected.

MANUALLY INITIATED ELECTRONIC DIAGNOSTICS

Use the following procedures to advance the filter through the recharge cycles to check operation.

Remove the top cover faceplate assembly by unlocking the tabs and lifting, to observe cam and switch operation during valve rotation (See Figure 28).

1. Press and hold for 3 seconds the SELECT button, until one of the screens shown in Figure 27 is displayed. If the valve is in service, backwash or aspirate position (observe markings on the valve cam), the display should show "000 - -", meaning the position switch is open. When the valve is moving, the display should show "000 - P", meaning that the position switch is closed.

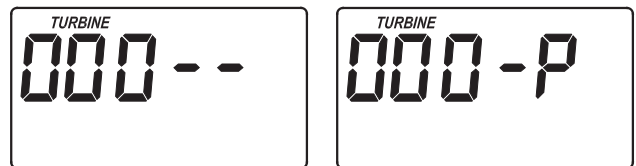

FIG. 27

2. Use the RECHARGE button to manually advance the valve into each position and check correct switch operation (See Figures 29-31).
3. While in the "aspirate" (A) position, check the nozzle & venturi by removing the screen from the barbed fitting on the inlet of the check valve and determining whether there is suction. Put the screen back in place when finished checking.
4. While in this diagnostic screen, the following information is available and may be beneficial for various reasons. This information is retained by the computer from the first time electrical power is applied to the electronic controller.
 - a. Press the ↑ UP button to display the number of days this electronic control has had electrical power applied.
 - b. Press the ↓ DOWN button to display the number of automatic or manual recharges initiated by this electronic control since the model code number was entered.
5. Press the SELECT button and hold in for 3 seconds until the model code shows in the display. The model code should be "HAAIF". If the wrong number shows, the filter will operate on incorrect configuration data.
6. To change the code number - Press the ↑ UP or ↓ DOWN button until the correct code shows.

continued on the next page

7. To return to the present time display, press the SELECT button. **If the model code was changed, make all controller settings.**

NOTE: If the electronic control is left in a diagnostic display (or a flashing display when setting times or hardness), present time automatically returns if a button is not pressed within 4 minutes.

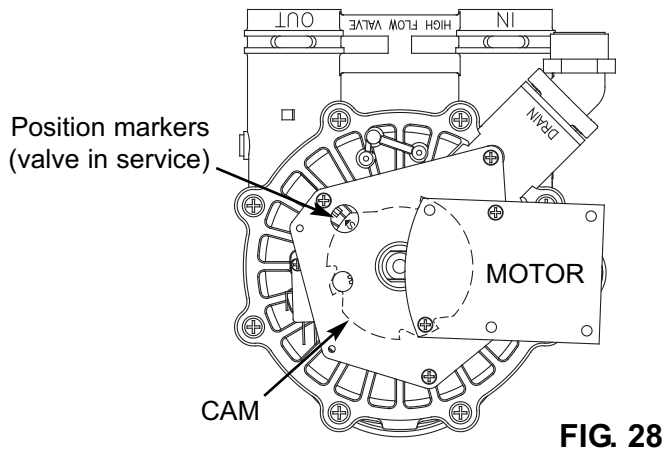

FIG. 28

RESETTING TO FACTORY DEFAULTS

To reset the electronic controller to its factory default for all settings (time, days between recharges, etc.):

1. Press the SELECT button and hold it until the display changes twice to show "CODE" and the flashing model code.



FIG. 32

2. Press the ↑ UP button (a few times, if necessary) to display a flashing "SoS".
3. Press the SELECT button, and the electronic controller will restart.
4. Set the present time, days between recharges, etc., as described on pages 10 & 11.

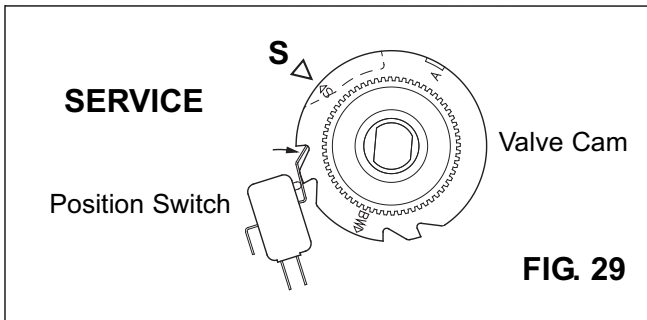

FIG. 29

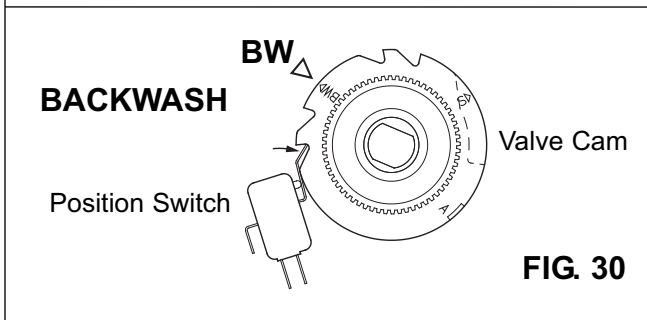

FIG. 30

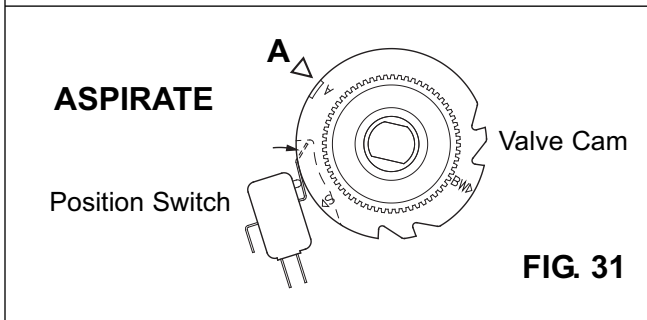

FIG. 31

TROUBLESHOOTING GUIDE		
PROBLEM	CAUSE	CORRECTION
Iron bleed	1. Riser tube o-ring.	1. Reseat or replace riser o-ring.
	2. Over-running filter bed.	2. Increase recharge frequency and backwash time.
	3. Time clock set incorrectly.	3. Check and change time.
	4. Increase in iron, hydrogen sulfide or manganese.	4. Increase recharge frequency and backwash time.
	5. Restricted drain line or drain flow control	5. Clear drain line or drain flow control.
	6. Plugged nozzle & venturi - no suction in aspirate cycle.	6. Clean nozzle & venturi (See Page 13).
Air in house lines	1. Riser tube o-ring.	1. Reseat or replace riser o-ring.
Water to drain	1. Defective rotor disc and seals.	1. Replace rotor disc and seals.

WIRING SCHEMATIC

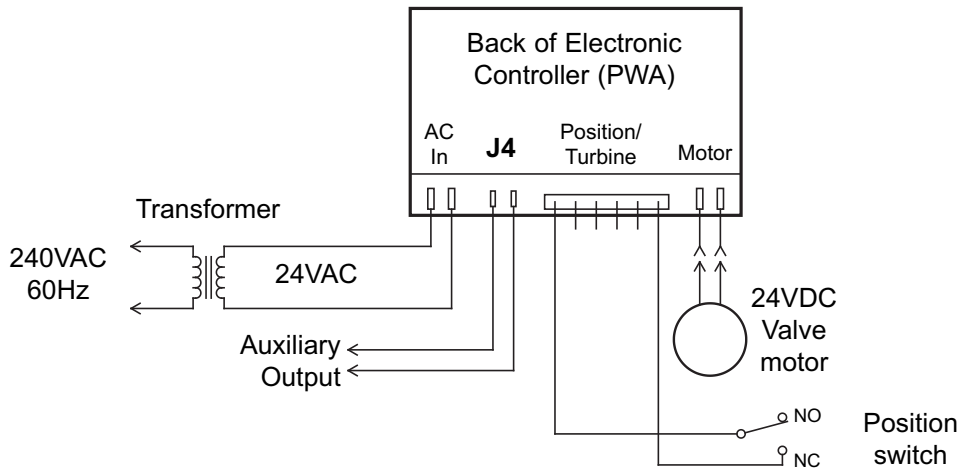
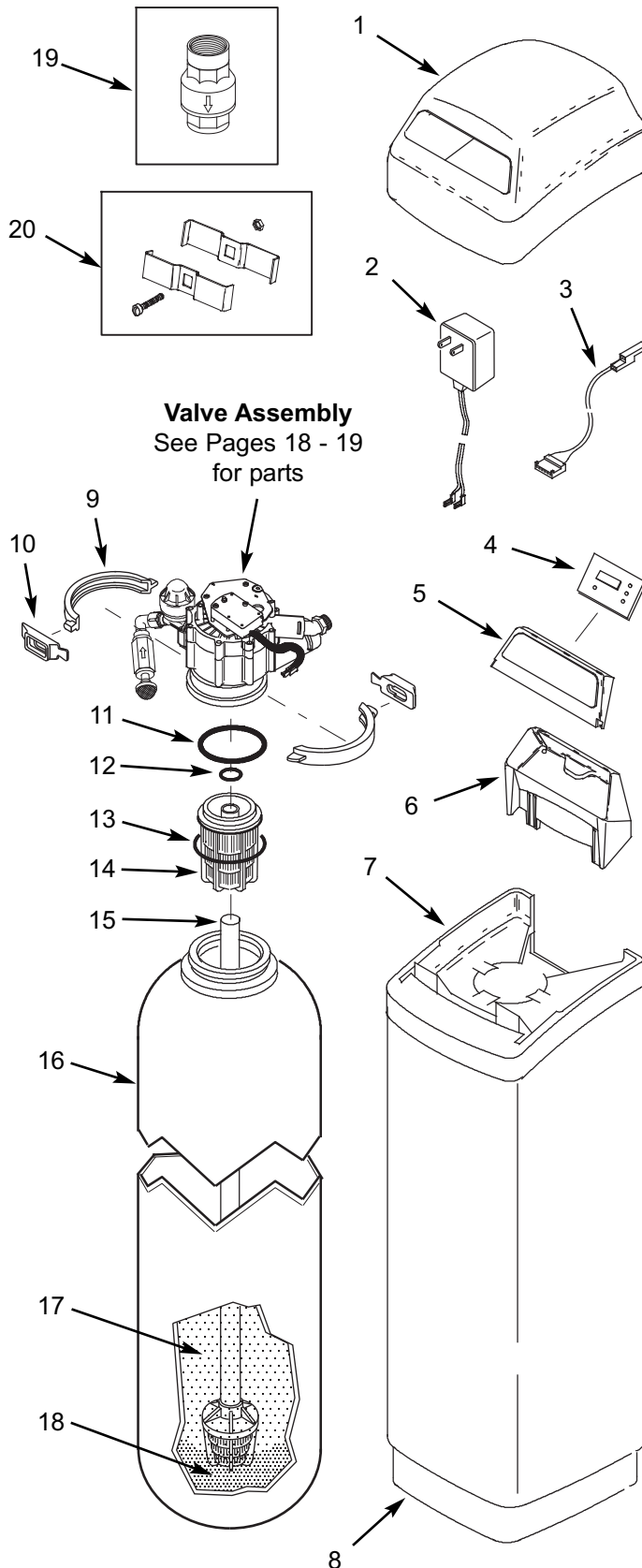

FIG. 33

FILTER EXPLODED VIEW



FILTER PARTS LIST

Key No.	Part No.	Description
1	7210478	Top Cover
2	7275907	Transformer, 120 V to 24 V, 10 VA
3	7259927	Wire Harness
4	7336363	Repl. Electronic Controller (PWA)
5	7210509	Faceplate (order decal below)
■	7308970	Decal, Faceplate
6	7211173	Support, Faceplate
7	7274286	Rim
8	7211068	Shroud, Model ETF 2100AIV-10
	7211050	Shroud, Model ETF 2100AIV-12
-	7331177	Tank Neck Clamp Kit (includes 2 ea. of Key Nos. 9 & 10)
9	↑	Clamp Section (2 req.)
10	↑	Retainer, Clamp (2 req.)
-	7112963	Distributor O-Ring Kit (includes Key Nos. 11-13)
11	↑	O-Ring, 2-7/8" x 3-1/4"
12	↑	O-Ring, 13/16" x 1-1/16"
13	↑	O-Ring, 2-3/4" x 3"
14	7335757	Top Distributor
15	7105047	Repl. Bottom Distributor
16	7092202	Repl. Mineral Tank, 10" x 47", Model ETF 2100AIV-10
	7113074	Repl. Mineral Tank, 12" x 54" Model ETF 2100AIV-12
17	7336656	Zeolite Media, 1 cu. ft.
18	7124415	Gravel, 17 lbs.
19	7336185	Inlet Check Valve, 1"
20	7248706	Ground Clamp Kit

■ Not illustrated

To order parts, call your local EcoWater dealer or go to www.ecowater.com to locate a dealer in your area.

VALVE EXPLODED VIEW

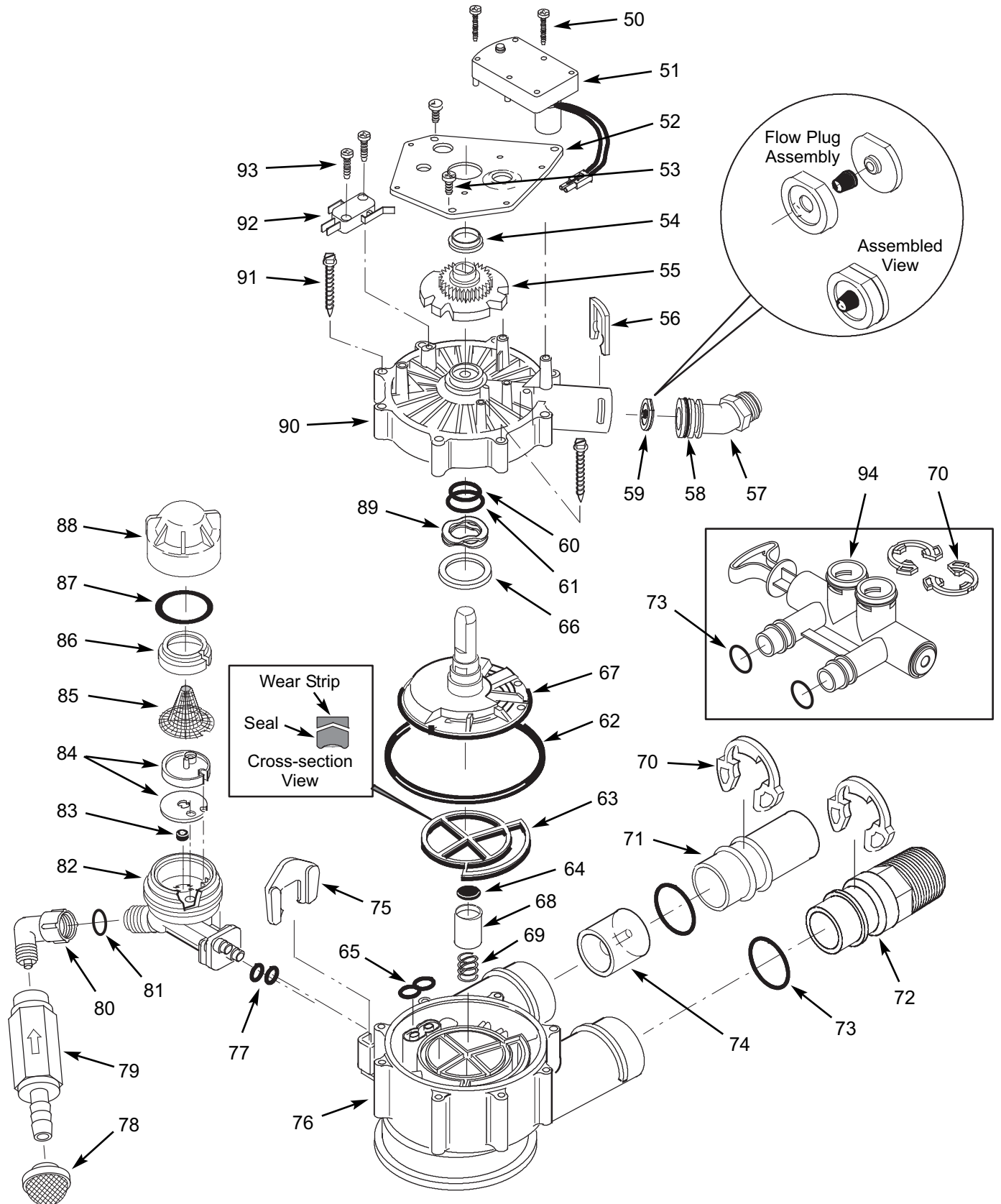

VALVE PARTS LIST

Key No.	Part No.	Description
50	7224087	Screw, #8-32 x 1" (2 req.)
51	7286039	Motor (incl. 2 ea. of Key No. 50)
52	7231393	Motor Plate
53	0900857	Screw, #6-20 x 3/8" (3 req.)
54	7171250	Bearing
55	7335024	Cam & Gear
56	7169180	Clip, Drain
57	7172793	Drain Hose Adaptor
58	7170288	O-Ring, 15/16" x 1-3/16"
59	7178202	Flow Plug, 7 gpm, Model ETF 2100AIV-10
	7178210	Flow Plug, 10 gpm, Model ETF 2100AIV-12
–	7185487	Seal Kit (includes Key Nos. 60-65)
60	↑	O-Ring, 5/8" x 13/16"
61	↑	O-Ring, 1-1/8" x 1-1/2"
62	↑	O-Ring, 4-1/2" x 4-7/8"
63	↑	Rotor Seal
64	↑	Seal
65	↑	Seal, Nozzle & Venturi
66	7174313	Bearing, Wave Washer
67	7335058	Rotor & Disc
68	7171187	Plug, Drain Seal
69	7129889	Spring
70	7089306	Clip (2 req.)
71	7077642	Copper Tube, 1"
72	7271204	1" NPT Threaded Adaptor

Key No.	Part No.	Description
73	7311127	O-Ring, 1-1/16" x 1-5/16" (2 req.)
74	7078240	Turbine Support & Shaft
75	7081201	Retainer, Nozzle & Venturi
76	7171145	Valve Body
77	7170319	O-Ring, 1/4" x 3/8" (2 req.)
78	7336208	Air Inlet Screen
79	7336193	Aspirator Check Valve
80	7120526	Elbow, 90°
81	7292323	O-Ring, 3/16" x 7/16"
–	7085247	Nozzle & Venturi Assembly (includes Key Nos. 82-88)
82	7081104	Housing, Nozzle & Venturi
83	1148800	Flow Plug, .3 gpm
84	7114533	Nozzle & Venturi Gasket Kit
	7204362	Gasket Only
85	7146043	Screen
86	7167659	Screen Support
87	7170262	O-Ring, 1-1/8" x 1-3/8"
88	7199729	Cap
89	7175199	Wave Washer
90	7171161	Valve Cover
91	7172997	Screw, #10 x 2-5/8" (8 req.)
92	7305150	Switch
93	7140738	Screw, #4-24 x 3/4" (2 req.)
94	7214383	Bypass Valve * (includes 2 ea. of Key Nos. 70 & 73)

* Optional parts, not included with filter

To order parts, call your local EcoWater dealer or go to
www.ecowater.com to locate a dealer in your area.

LIMITED WARRANTY
EcoWater Systems LLC Advantage Warranty
Series ETF AIV Water System

Congratulations! You have just purchased the highest quality water conditioning product on the market. To register your warranty, complete the enclosed Warranty Registration Card and mail it within 30 days of purchase.

To whom is this warranty extended?

EcoWater Systems LLC warrants its products to the original owner and guarantees that the products will be free from defects in materials and workmanship from the original date of installation.

How does my warranty work?

If, during the respective warranty period, a part proves, after inspection by EcoWater, to be defective, EcoWater will, at its sole option repair or replace that part at no charge, other than normal shipping, installation or service charges.

What is covered by the warranty?

EcoWater Systems LLC guarantees that, for the LIFETIME of the original owner, the MINERAL TANK will not rust, corrode, leak, burst, or in any other manner fail to perform its proper functions and that, for a period of FIVE (5) YEARS after installation, the VALVE BODY will be free of defects in materials and workmanship and will perform its proper function and that, for a period of THREE (3) YEARS after installation, the ELECTRONIC FACEPLATE will be free of defects in materials and workmanship and will perform its normal functions, and that, for a period of ONE (1) YEAR after installation, all other parts will be free of defects in materials and workmanship and will perform their normal functions.

How do I obtain warranty service?

Should you need service, your local, independent EcoWater Dealer is only a phone call away.

PHONE: _____

To obtain warranty service, notice must be given, within thirty (30) days of the discovery of the defect, to your local EcoWater Systems dealer.

If I need a part replaced after the factory warranty expires, is the replacement part warranted?

Yes, EcoWater Systems LLC warrants FACTORY REPAIRS as well as all REPLACEMENT PARTS for a period of 90 DAYS. This warranty does not include normal shipping, installation or service charges.

Are any additional warranties available?

We are pleased to say, YES! EcoWater Systems LLC sells an EXTENDED, PARTS ONLY WARRANTY for the ELECTRONICS portion of your product. This warranty is called the "Perfect Ten" and extends the three year warranty on the electronic FACEPLATE, WIRING HARNESS, DRIVE MOTOR, TRANSFORMER, POWER CORD, SENSOR HOUSING, and MICRO SWITCHES to a total of TEN YEARS from the date of original installation. Your local dealer will provide details regarding this warranty or will refer you to the factory for additional information. Should your local dealer not offer this warranty, you may contact the factory for additional information.* This guarantee may be subject to normal shipping and installation or service charges.

General Provisions

The above warranties are effective provided the water conditioner is operated at water pressures not exceeding 80 psi, and at water temperatures not exceeding 120°F; provided further that the water conditioner is not subject to abuse, misuse, alteration, neglect, freezing, accident or negligence; and provided further that the water conditioner is not damaged as the result of any unusual force of nature such as, but not limited to, flood, hurricane, tornado or earthquake. EcoWater Systems LLC is excused if failure to perform its warranty obligations is the result of strikes, government regulation, materials shortages, or other circumstances beyond its control.

*THERE ARE NO WARRANTIES ON THE WATER CONDITIONER BEYOND THOSE SPECIFICALLY DESCRIBED ABOVE. ALL IMPLIED WARRANTIES, INCLUDING ANY IMPLIED WARRANTY OF MERCHANTABILITY OR OF FITNESS FOR A PARTICULAR PURPOSE, ARE DISCLAIMED TO THE EXTENT THEY MIGHT EXTEND BEYOND THE ABOVE PERIODS. THE SOLE OBLIGATION OF ECOWATER SYSTEMS LLC UNDER THESE WARRANTIES IS TO REPLACE OR REPAIR THE COMPONENT OR PART WHICH PROVES TO BE DEFECTIVE WITHIN THE SPECIFIED TIME PERIOD, AND ECOWATER IS NOT LIABLE FOR CONSEQUENTIAL OR INCIDENTAL DAMAGES. NO ECOWATER DEALER, AGENT, REPRESENTATIVE, OR OTHER PERSON IS AUTHORIZED TO EXTEND OR EXPAND THE WARRANTIES EXPRESSLY DESCRIBED ABOVE.

Some states do not allow limitations on how long an implied warranty lasts or exclusions or limitations of incidental or consequential damage, so the limitations and exclusions in this warranty may not apply to you. This warranty gives you specific legal rights, and you may have other rights which vary from state to state. This warranty applies to consumer-owned installations only.